

Underwater Welding – A Review

Niraj Kumar¹, B. S. Patra², Goutam Mishra³, Pradyut Kumar Swain⁴

¹Department of Mechanical Engineering, Raajdhani Engineering College, Bhubaneswar, Odisha

²Department of Mechanical Engineering, NM Institute of Engineering and Technology, Bhubaneswar, Odisha

³Department of Mechanical Engineering, Capital Engineering College, Bhubaneswar, Odisha

⁴Department of Mechanical Engineering, Aryan Institute of Engineering and Technology Bhubaneswar, Odisha

Abstract

The paper describes principles of underwater welding and recent trends in research works undertaken for enhance welding technology and properties of underwater welds. Department of Materials Technology and Welding at Gdansk University of Technology (GUT) has been involved in underwater welding research for over 25 years. Investigations include technology of underwater welding, and weld properties examinations. All tests have been performed with the use of self-designed stands allow to perform welds in shallow depths as well as the depths up to 1000 m. The main investigation directions performed at the Department of Materials Technology and Welding are presented:

- Weld ability of HSLA steel and factors influencing susceptibility to cold cracking of welded joints.
- The effects of wet welding conditions on diffusible hydrogen amount in the welds.
- The effects of heat input, underwater welding depths and composition of shielded gases on welds toughness.

Key words: *underwater welding, wet welding, dry welding, local cavity, weld ability of steel*

INTRODUCTION

For nearly thirty years underwater welding techniques have been investigated at Department of Materials Technology and Welding at GUT. Few original test stands were constructed in laboratories and then utilized for determination welding parameters and properties of welded joints. The main investigation directions at the Underwater Welding Laboratory are wet shielded metal arc welding and gas metal arc welding in local cavity method [1,2], additional works are performed with the use of underwater cutting techniques [2,3].

When it is not possible to place metal structure into a dry dock, welding operations must be performed in water environment [2,4,5,6,7]. Underwater welding techniques can be classified as follows [2,4,8]:

- a) wet welding,
- b) dry welding,
- c) local cavity welding.

The review of modern underwater welding processes is presented in current paper. The attention is focused especially on wet and local cavity welding.

UNDERWATER WELDING TECHNIQUES

The classification of underwater welding techniques is presented in Fig. 1.

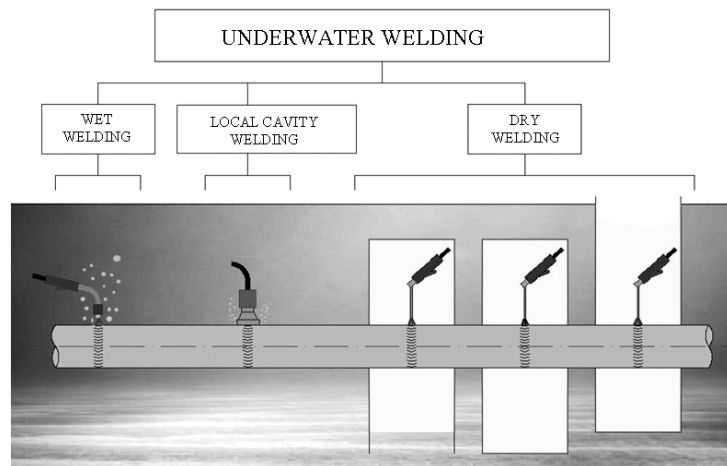

Fig. 1. Classification of underwater welding

Wet welding is performed at ambient pressure with the welder-diver in the water and no mechanical barrier between water and welding arc. Simplicity of the process makes it possible to weld even the most geometrically complex structures [5,6,9,10]. The most commonly used wet welding technique is shielded metal arc welding (SMAW) and flux cored arc welding (FCAW) including self shielded flux cored arc welding. Wet welding with coated electrodes is considered to be the most cheap and versatile method of operations in underwater environment [5,6,9,10]. Wet welding with covered electrodes or FCAW is conducted directly in water environment down to 100 meters [10]. In water environment cooling rate in wet welds is much higher than in those obtained in dry welding. In the temperature range from 800 to 500°C it can change from 415 to 56 °C/s [11]. This causes a loss of ductility of weld metal and of heat affected zone (HAZ). Underwater wet welds are also known to contain high amounts of porosity (Fig. 2). Porosity may be formed by molecular hydrogen, carbon monoxide or water vapor [12,13,14]. Pores are present to some extent in all wet welds. The main factors affecting this phenomenon are [10,12,13,14]: water depth, electrode covering and arc stability.

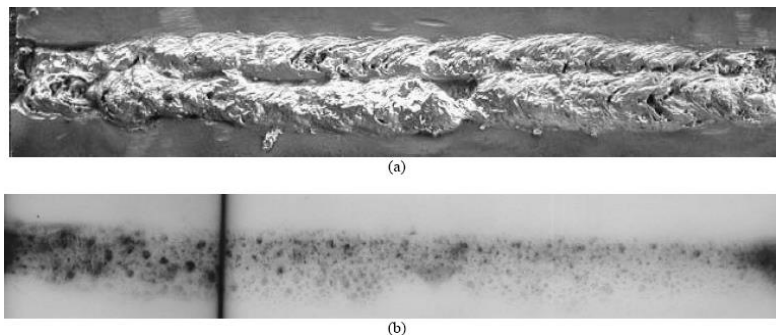

Fig. 2. V-groove wet weld deposited at 100 m depth (a) and its radiographic image (b) [15]

During last years the quality of wet welds has been improved. Commercially available modern electrodes and flux cored wires of special type ensure good quality of welded joints [6,16,17].

Welding by local cavity method is possible due to utilizing standard equipment for semiautomatic or automatic gas metal arc welding (GMAW) [18,19] instrumented additionally with special outer nozzle and elastic cover as it is shown in Fig. 3. In local cavity method cooling conditions are nearly the same as those existed during welding in the air [20]. Results of diffusible hydrogen determination tests indicate that amount of hydrogen in weld metal is in the range from 5 to 21 ml/100g Fe and depends on welding parameters, especially flow rate of shielding gas [18,19]. Properties of welds performed with the use of local dry chamber are much better than properties of wet welds and meet requirements of classification societies for depth up to 200 m [21,22]. View of exemplary weld beads obtained by local cavity welding is presented in Fig. 4. The main disadvantage of the method is lack of possibility of welding process observations. Local cavity process can be also performed with application of laser beam as a heat source [23].

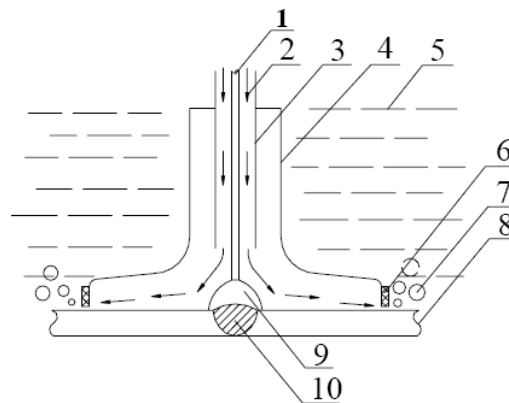

Fig. 3. Welding by local cavity method. 1 – welding nozzle, 2 – welding wire, 3 – shielding gas, 4 – outer nozzle, 5 – water, 6 – elastic cover, 7 – gas bubbles, 8 – welded element, 9 – arc, 10 – weld

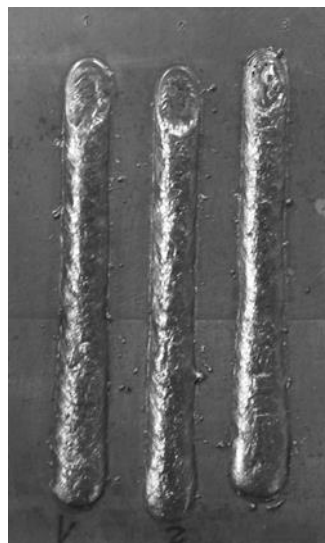

Fig. 4. Weld beads obtained by local cavity welding

Dry hyperbaric welding is performed at ambient pressure in a chamber (Fig. 5) where water has been displaced with air or a gas mixture, depending on depth. Underwater dry welds in comparison with those obtained in wet conditions are of better quality, but large support equipment is required and involved costs are relatively high [4,7,24]. In many cases dry welds have mechanical properties equal to similar welds performed above water. Estimated cost and time for dry welded repairs are twice that for wet welded repairs [5]. In dry conditions there is a possibility to use almost all standard methods of welding. The most commonly used welding techniques are [4,7,25]: SMAW, GMAW, FCAW, and tungsten inert gas welding (TIG). The maximum depth for using manual hyperbaric welding is 300 m.

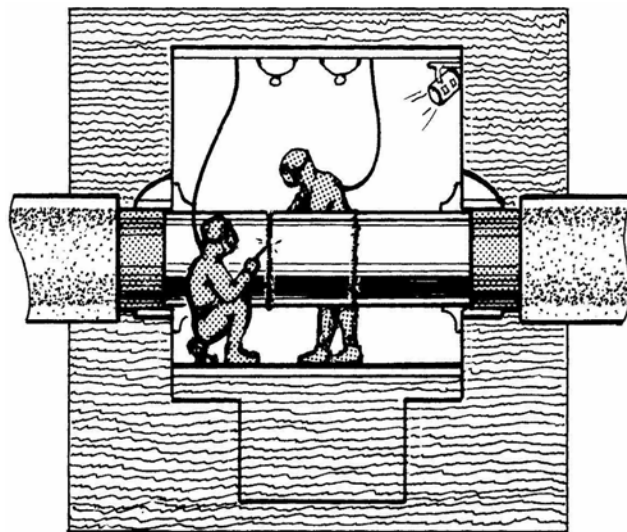

Fig. 5. Underwater welding in dry conditions

WELDABILITY OF STEEL IN WATER ENVIRONMENT

Underwater welding is more difficult in comparison to that performed at open air because of: higher pressure, hydrogen content in weld metal and higher cooling rates [2,4,8,11,26,]. It has been proved that increased pressure makes welding arc unstable and the presence of diffusible hydrogen and brittle microstructures in the welds can be the reasons of cracks formation [4,8,10].

In the most cases underwater welding is used for joining carbon steels, low alloy steels, austenitic and duplex stainless steels [2,4,12]. Weldability of steel in water environment is governed by its cold or hot cracking tendency [28,29,27,30]. Susceptibility to cold cracking is main problem in welding of high strength low alloy steels (HSLA) (Fig. 6) and fabrication of dissimilar joints. Hot cracks in the most cases are observed in weld metal of fully austenitic stainless steels (Fig. 7). There are relatively numerous publications on this subject [4, 9, 18,27,28,31,13].



Fig. 6. Microphotograph of the cold crack in the bainite structure of heat affected zone [18]

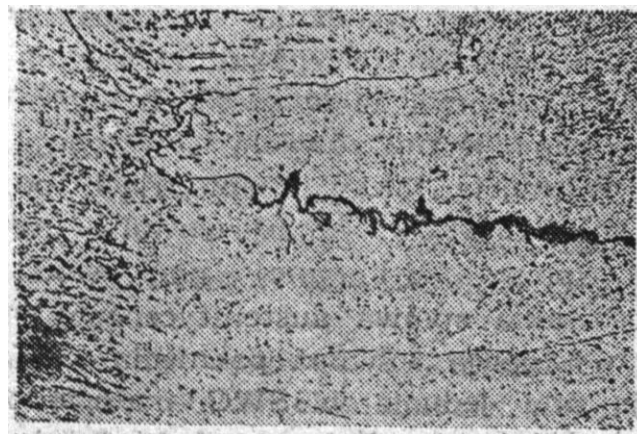

Fig. 7. Microphotograph of the hot crack in austenitic weld metal [30]

Welded joints of high strength steels performed in wet underwater conditions are very susceptible to cold cracking (hydrogen cracking) [27,28,30]. For eliminate tendency to cracking the effect of three factors: amount of diffusible hydrogen, hard microstructures in HAZ and high residual stresses in the weld joint should be minimized [33,34,35]. Reduction of the hydrogen content can be obtained with the use of consumables which give low amount of hydrogen in welds or by selecting welding parameters which minimize weld pool hydrogen pickup [19,36].

Unfavorable structure transformations in HAZ can be avoided by controlling of cooling rate of welded joint by the use of special insulation on surface of the welded plate and apply high heat inputs [11,36]. Welding practices that reduce residual stresses in the joints include: the use of small weld deposits and consumables with compatible coefficients of thermal expansion with base material and the selection of edge preparations which reduce weld deposit.

The strength of the steel used for the deep-water structures is very important factor, because high strength steel (yield strength over 350 MPa) is required at greater depths. High strength steels usually have carbon equivalents greater than 0.4% and show worse weldability.

INVESTIGATIONS PERFORMED IN DEPARTMENT OF MATERIALS TECHNOLOGY AND WELDING

Although underwater welding by local cavity method ensures cooling conditions nearly the same as during welding in the air [2,8], cold cracks can occur in high strength steel welded joints. So the aim of undertaken research was determination of susceptibility to cold cracking of the joints performed in underwater conditions by local cavity method. For that purpose HSLA S355 (18G2A) steel was selected together with matching filler materials for GMAW process. There are only a few papers on this subject and the results reported by authors are not in full agreement [2,8,18,20]. Chemical composition of tested material is given in table 1.

Table 1. Chemical composition of S355 (18G2A) steel, wt %

C	Mn	Si	Cr	Ni	Cu	Al
0.17	1.44	0.35	0.04	0.077	0.30	0.027

Test welds were made at the stand for underwater welding (Fig. 8) employing GMAW process and with the use of IS-10S wire ($\Phi = 1.2$ mm).

Susceptibility to cold cracking was carried out by implant method. Implant specimens were performed at the following conditions: heat input $e_L = 10 \div 20$ kJ/cm and shielding gas (CO_2) flow rate of $W_g = 20 \div 50$ l/min [18]. Cylindrical notched specimen of the test material was inserted into a borehole of backing plate and then welded to it by one bead. The specimen was subjected to a static tensile loading on “Implant 02” stand showed in Fig. 9. The time to fracture was recorded. The tensile load was maintained for 16 hours if the specimen had not failed before [18].

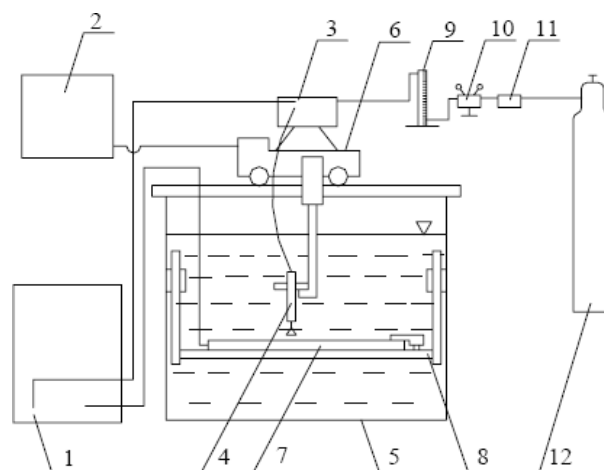

Fig. 8. Test stand for underwater welding

- 1 – power source, 2 – track feeder, 3 – engine, 4 – head, 5 – water container,
 6 – welding track, 7 – specimen, 8 – work piece holder, 9 – flow meter,
 10 – reducer, 11 – preheater, 12 – gas cylinder



Fig. 9. Test stand "Implant 02" [37]

Glycerin method was used for evaluation of diffusible hydrogen content in the weld metal. The amount of hydrogen was determined in the range from 10 to 21 ml/100g Fe. The hydrogen amount strongly depends on flow rate of shielding gas. Regression analysis for obtained results was performed with the aid of the Statistica software package. Using critical stress σ_{cr} as dependent variable, W_g and e_L as independent variables the following regression equation was obtained:

$$\sigma_{cr} = - 184,81 + 14,59 \times W_g - 0,24 \times W_g^2 + 39,33 \times e_L - 1,33 \times e_L^2 + 0,13 \times W_g \times e_L,$$

where:

- σ_{cr} – critical stress [MPa],
- W_g – flow rate of shielding gas [l/min],
- e_L – heat input of welding [kJ/cm].

with $R^2=0.995$ (determination coefficient) and $p=0,05$ (level of significance). The relation can be presented graphically (Fig. 10).

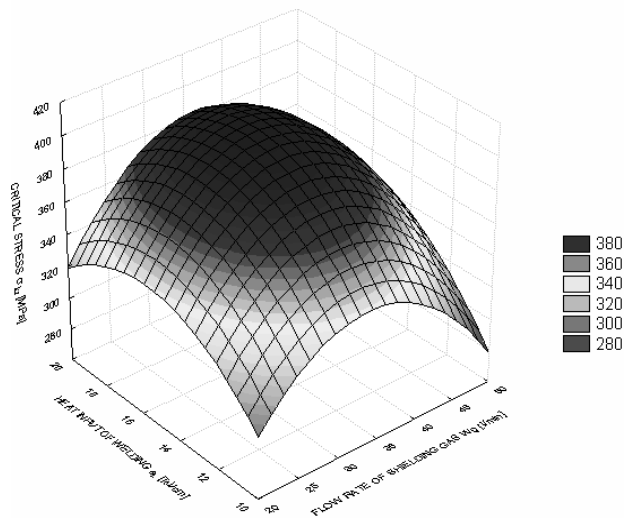

Fig. 10. Relationship between critical stress σ_{cr} and flow rate of shielding gas W_g and heat input e_L for underwater welds [18]

The obtained model allows optimization of welding parameters. The surface area shown in Fig. 10 reaches its maximum at following values: $W_g=35$ l/min and $e_L=16$ kJ/cm. Other investigations were aimed at the determination of diffusible hydrogen content in weld metal after wet underwater welding using of covered electrodes [36]. Problem has been solved by the use of design of experiment method (Plackett-Burman design). Test welds (Fig. 11) were performed at the stand for welding on low depths (Fig. 8) with application of various welding conditions: welding current, painting of electrode, electrodes polarity, thickness of flux covering electrodes core, salinity of water, contamination of electrode (carbohydrates) and time of wetting of electrode in water. To evaluate the diffusible hydrogen content in the weld metal glycerin method was used [38]. The results of these experiments are collected in table 2. The amount of hydrogen was determined in the range from 45.90 to 87.40 ml/100g Fe.



Fig. 11. Specimens with test beads obtained by wet underwater welding conditions with the use of covered electrodes

The results of analysis performed in Statistica software (fig. 12) show that the most relevant variables are: salinity of water, contamination of electrode, electrode polarity and welding current [36].

Table 2. Conditions and results of diffusible hydrogen measurements [36]

No	Welding current [A]	Thickness of covering [mm]	State of electrode	Painting	Salinity of water [‰]	Polarity	Time in water [min]	Average hydrogen amount H_D [ml/100 g Fe]
1	240	0.90	pure	yes	10	+	5	45.90
2	292	0.90	pure	no	0	+	0	70.46
3	240	1.35	pure	no	10	-	0	47.27
4	292	1.35	pure	yes	0	-	5	74.17
5	240	0.90	oil	yes	0	-	0	87.40
6	292	0.90	oil	no	10	-	5	71.11
7	240	1.35	oil	no	0	+	5	83.98
8	292	1.35	oil	yes	10	+	0	63.95
9	240	1.35	oil	no	0	+	5	79.48

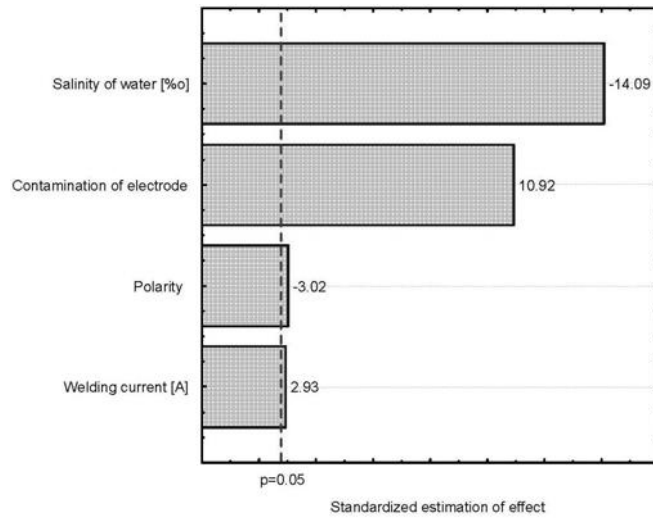

Fig. 12. Pareto chart of the standardized effects [36]

Following investigations aimed at determination of shielding gas and water depth on impact strength of joints made under water by local cavity method. Test welds were made on test stand for underwater welding on high depths (Fig. 13) using GMAW process with CO₂ and Ar+CO₂ shielding gases [39].



Fig. 13. Test facility for simulating underwater welding on high depths

Specimens were sampled from test joints made in following conditions: depth of water up to 200 m, heat input from 1.53 to 4.38 kJ/mm. Impact strength was measured on Charpy V specimens at room temperature. As it can be seen from fig. 14, up to 60 m water depth difference in values of impact strength is relatively low, but in the range 60÷100 m for welding in mixed gas Ar+CO₂ the drop of impact strength is observed. The results of these experiments indicated that it is recommended to use only pure argon as a shielding gas when welding is performed on depths lower than 60 m [39].

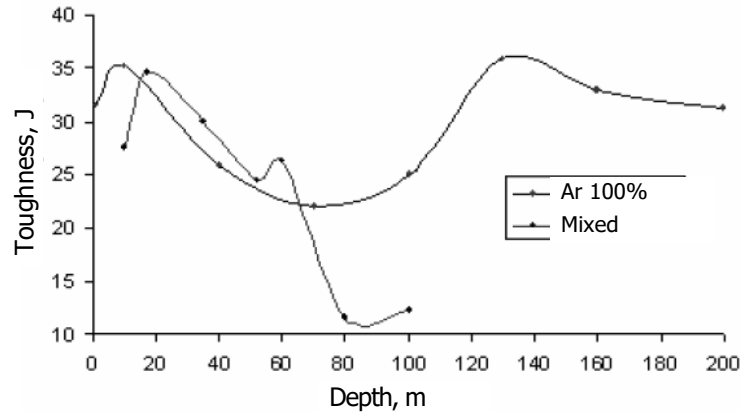

Fig. 14. The influence of underwater welding depth and shielded gas composition on welds toughness [39]

SUMMARY

Modern techniques of underwater welding give possibility of obtaining joints with sound welds that meets requirements of classification societies. Recent improvements in underwater welding have led to the increased use of wet and dry hyperbaric welding for marine applications. But more spread application of wet welding methods is limited due to common opinion of low quality of welds performed by this method [2,4,8,10,11,24]. The general acceptance of underwater welding processes has been further advanced by the standardization of methods, procedures, and certification requirements provided by the American National Standards Institute and American Welding Society[40].

In spite of many successful applications and results of investigations, underwater welding requires new research and development to achieve its full potential.

REFERENCES

1. Lesiński K. J.: State of the art of underwater cutting and welding. Proceedings of conference „Problems of underwater cutting and welding”, Gdańsk University of Technology, Gdańsk 1985 (in Polish).
2. Lesiński K.J., Piątkowski T., Kielczyński W.: Evaluation of quality of welds obtained by underwater welding - stage I. Report. Gdańsk University of Technology, Gdańsk 1989 (in Polish).
3. Lesiński K. J.: Semiautomatic underwater cutting. Proceedings of conference „Problems of underwater cutting and welding”, Gdańsk University of Technology, Gdańsk 1985 (in Polish).
4. Cotton H. C.: Welding under water and in the splash zone – a review. Proceedings of the International Conference „Underwater Welding”, Trondheim, Norway 1983.

5. Grubbs C. E., Reynolds T. J.: Underwater welding: seeking high quality at greater depths. *Welding Journal* 9/1998.
6. Kononenko V. Ya.: Technologies of underwater wet welding and cutting. E. O. Paton Electric Welding Institute, Kiev, Ukraine 2000.
7. Szelagowski P., Pachniuk I.: State of the art and practice of underwater hyperbaric dry welding. International workshop on underwater welding of marine structures. New Orleans, USA, 1994.
8. Christensen N.: The metallurgy of underwater welding. Proceedings of the International Conference „Underwater Welding”, Trondheim, Norway 1983.
9. Grubbs C. E., Reynolds T. J.: State-of-the-art underwater wet welding - offshore oil fields. *World Oil* 8/1998.
10. Ibarra S., Grubbs C. E., Liu S.: State of the art and practice of underwater wet welding of steel. International workshop on underwater welding of marine structures. New Orleans, USA, 1994.
11. Chigariev V. V., Ustinov A. V.: Design-experimental estimation of the possibility of reduction of the HAZ metal cooling rate in wet underwater welding. *The Paton Welding Journal* 5/2000.
12. Liu S., Pope A., Daemen R.: Welding consumables and weldability. International workshop on underwater welding of marine structures. New Orleans, USA, 1994.
13. Pessoa E., Bracarense A., Zica E., Liu S., Guerrero F.: Porosity variation along multipass underwater wet welds and its influence on mechanical properties. *Journal of Materials Processing Technology* 179/2006.
14. Rowe M., Liu S., Reynolds T. J.: The effect of ferro-alloy additions and depth on the quality of underwater wet welds. *Welding Journal* 08/2002.
15. Rowe M., Liu S.: Final report MT-CWJCR-099-032. Global Industries, 1999.
16. www.specialwels.com.
17. www.pommec.com
18. Fydrych D.: Effect of welding conditions on susceptibility to cold cracking of welds obtained under water. Ph. D. thesis. Gdańsk University of Technology, Gdańsk 2005 (in Polish).
19. Łabanowski J., Fydrych D.: Investigations of underwater welding processes. Report, Gdańsk University of Technology, Gdańsk 2008.
20. Rogalski G.: Determination of welding thermal cycles during underwater welding. Proceedings of Doctorate Studies Conference, Gdańsk 2003 (in Polish).
21. Lesiński K. J.: Technology of welding by local cavity process up to 200 m - stage I. Report. Gdańsk University of Technology, Gdańsk 1987.
22. Lesiński K. J.: Technology of welding by local cavity process up to 200 m - stage II. Report. Gdańsk University of Technology, Gdańsk 1987.
23. Zhang X., Ashida E., Shono S., Matsuda F.: Effect of shielding conditions of local dry cavity on weld quality in underwater Nd:YAG laser welding. *Journal of Materials Processing Technology* 174/2006.

24. Gooch T. G.: Properties of underwater welds. *Met. Con.* 1983, 'Part 1 Procedural trials' 15(3) 164-167; 'Part 2 Mechanical properties' 15(4) 206-215.
25. Ibarra S.: Shallow underwater welding. International workshop on quality in underwater welding of marine structures. Golden, USA, 1985.
26. Johnsen M. R.: Keeping shipshape through underwater welding. *Welding Journal* 11/2001.
27. Bohme D., Eisenbeis C.: Investigation into the credibility of the implant test when used to assess the cold cracking sensitivity of underwater wet welds. Proceedings of the International Conference „Welding Under Extreme Conditions”, Helsinki, Finland 1989.
28. Brink S. H., Boltje G. W.: Cold cracking susceptibility of welds obtained by wet underwater welding. Proceedings of the International Conference „Underwater Welding”, Trondheim, Norway 1983.
29. Fydrych D., Kozak T.: Effect of welding conditions on susceptibility to cold cracking of underwater welded joints. Proceedings of International Conference, Bremen 2006.
30. Tasak E., Bal M.: Properties of wet welds obtained by covered electrodes. *Przegląd Spawalnictwa* 1-2/1985.
31. Matsuda K., Masumoto I., Hasegawa M.: Study on the crack sensitivity of mild steel welded joint by underwater welding. Proceedings of the International Conference „Joining of Metals – 2”, Helsingor, Denmark 1984.
32. Ozaki H., Naiman J., Masubuchi K.: A study of hydrogen cracking in underwater steel welds. „*Welding Journal*” 8/1977.
33. Bailey N.: Weldability of ferritic steels. Abington Publishing, Abington Hall, Cambridge, England 1994.
34. Butnicki S.: Weldability and brittleness of steel. Wydawnictwa Naukowo-Techniczne, Warszawa 1991 (in Polish).
35. IIW Doc. IX-1970-00 Pokhodnya I. K., Shvachko V. I.: Physical nature of hydrogen-induced cold cracks in welded joints in structural steels.
36. Fydrych D., Rogalski G.: Effect of shielded-electrode wet welding conditions on hydrogen content in deposited metal. *Przegląd Spawalnictwa* 2/2008.
37. Kozak T., Fydrych D.: Weldability of constructional materials. Report BW 01469303, Gdańsk University of Technology, Gdańsk 2004.
38. Kotecki D. J.: Hydrogen reconsidered. *Welding Journal* 8/1992.
39. Fydrych D., Rogalski G.: Investigations of underwater welding processes. Report BW, Gdańsk University of Technology, Gdańsk 2007.
40. AWS D3.6M: 1999: Specification for underwater welding, American Welding Society, Miami, USA 1999.